

Building the regulator board:

Parts needed:

line cord, fuse and switch.

1 center tapped transformer, 8-12 VAC, 0.5 A or bigger

1 Full wave bridge rectifier, 30Volt or bigger, 1.5 Amp or bigger

2 capacitors, 2700 uf or bigger, 16 volt or bigger

2 7805 voltage regulators

1 7905 voltage regulator

6 capacitors, 0.1 uf

stack pins as chosen by the user

OK, we start with the power supply. This power supply is intended to power the mixer circuits only. Powering the core and display from this could add noise to your mixer. Half the supply is off the circuit board, as it just won't fit. We will start with the transformer. Wire the primary side with the fuse and power switch you have chosen. The secondary side should have three wires. Two are the 8VAC windings, and the middle one is the center tap. The transformer must be a center tapped type for this project. If there are four wires, read the transformer documents to see which two should be connected as the center tap. If you have a multimeter, you can test it by setting the meter to AC voltage, connect the black lead to the center tap, and check each of the other secondary leads with the red lead. Each should read about 8 volts. If one reads eight and the other 16, you have the black lead on

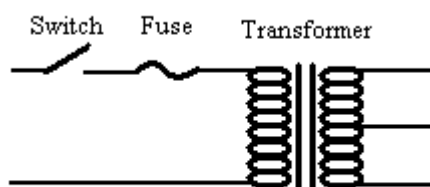

the wrong wire. So far, it looks like this:

OK, now we rectify it to DC. We connect the transformer 8VAC windings to the AC leads of the bridge (marked "~"). We connect the + lead of one capacitor to the + side of the bridge and the + terminal of the regulator board. We connect the - lead of the other capacitor to the - side of the bridge and the - terminal of the regulator board. Finally, we connect the two loose capacitor leads, and the transformer center tap, to the center terminal of the regulator board connector. Now it should look something like this:

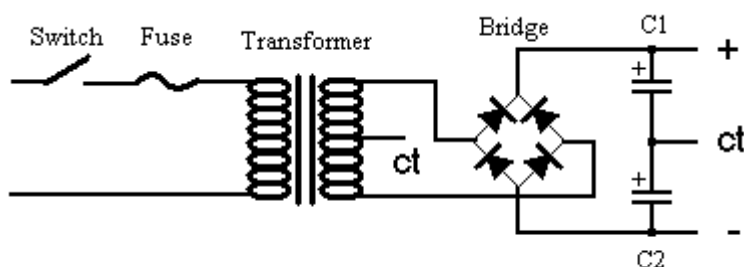

Before connecting to the regulator board, we are ready for our first test. Carefully insulate all AC connections. Set your meter to AC volts. Connect power and turn the switch ON. Connect your black meter lead to the center connector pin. Touch the red lead to each of the AC terminals of the bridge ("~"). Each one should read about 8 Volts AC. Now switch your meter to DC volts and keep the black lead on the center terminal. Touch the red lead to the "+" and "-" connector pins. The plus side should read above +8 volts DC, and the negative should read below -8 volts DC. If these tests pass, clean up your wiring and we will go on to stuffing parts into the regulator board.

The bare regulator board looks like this:

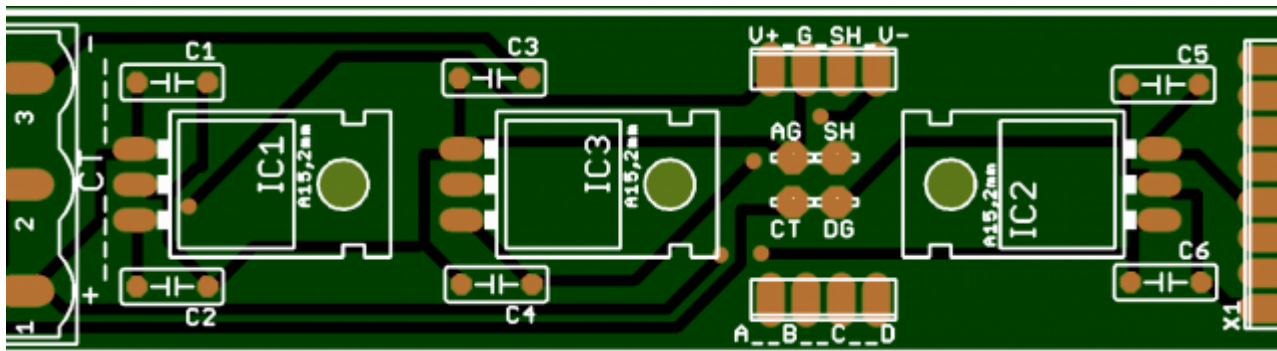

Add 0.1 uf capacitors to all six positions C1 to C6, two near each regulator. These can face either way. (not polarized).after soldering the leads onto the board, cut off and save the excess wire leads. Now find the four holes between regulators IC2 and IC3. These holes are marked "AG", "SH", "CT", and "DG". Use the wire clippings from the capacitors to join all four of these together. These are the four grounds of the system, and this is the ONLY place they should be be joined together. They are "Analog Ground", "Shield", "Center Tap", and "Digital Ground". You may leave a loop here as a handy place to connect your meter for testing. The place where these four are joined will be called "Ground Zero". So we have the caps installed and the grounds joined. Now we add the 3 pin connector for incoming power, if you have not done so already. Now the regulators. IC1 and IC2 are 7805 regulators. IC3 in the middle is a 7905. Bend the leads of each so that the regulators are just above the board surface. For this project, heat sinks should not be needed. Before adding the stack pins we should test one more time. Set your meter to DC volts, connect the black lead to "Ground Zero". Turn on the power,and check the pin marked "V+" above ground zero. It should read +5 volts. Check the "V-" pin above ground zero, it should read -5 volts. Finally, over on the right on the "Digital I/O pins, count up from X1 to the fourth pin. That should also read +5 volts. If all these tests pass, we only need to add stack pins to complete this board.

Because this board is the bottom of the stack, we don't need the pins to reach below the board. We really only need them to grab the pins coming down from the board above us. Most of the pins coming down will not be used. The only required pins for this board are the four pins above ground zero, and the bottom and fourth pins of the digital I/O section. The other four below Ground Zero and the other six on the digital connector are there for board support only. Add whatever pins you are using, solder well, then trim flush to the bottom of the board. The regulator board is complete.

From: <http://www.midibox.org/dokuwiki/> - **MIDIbox**

Permanent link: <http://www.midibox.org/dokuwiki/doku.php?id=pga:buildregbrd>

Last update: **2008/09/07 22:38**

