

A bipolar powersupply with +-12 V

For many circuits, especially when using op amps, we need a PSU that delivers +12 V, -12V and ground. The OPL3 module (used by Midibox FM), as well as an AOUT* module in bipolar operation, require a +/- 12 VDC supply. This page will demonstrate different methods of building such a supply.

Safety first!

Mains voltage can kill you!!! Use Fuses and your head when working with PSUs!!!

Old safety rule: When working with mains voltages, keep your left hand in your pocket. Concentrate on what your right hand is doing. That's enough. Triple check that capacitors are connected in the correct polarity and have the right voltage rating. They can explode otherwise, and the big ones will make a mess! Similarly, a rectifier installed incorrectly can overheat and melt very quickly. Anything smells funny? Strange noises? **Power off!**

Three Methods

Center Tap Transformer

The first method uses a 30 V transformer with center tap, or two 15 V transformers in series. The voltage is rectified and applied to a standard stabilizing circuit using caps and 7812/7912 voltage regulators. Why 15 V when we need 12 V? There is a voltage drop over the diodes in the rectifier. The mains supply may also be lower than it is rated, which will also reduce the output of your transformer. The regulators need a voltage 3 V higher than their output to work correctly. Many small print transformers will give more than their rated voltage when little current is drawn. So in many cases 12 V transformers can also be used. Build the whole circuit and measure at the input of the 7812. You should have little more than 15 V at this point. In fact the 7812 is rated for an input voltage of 14.5 V-35 V. Again, don't forget that our mains supply can vary between +5% and -10%!

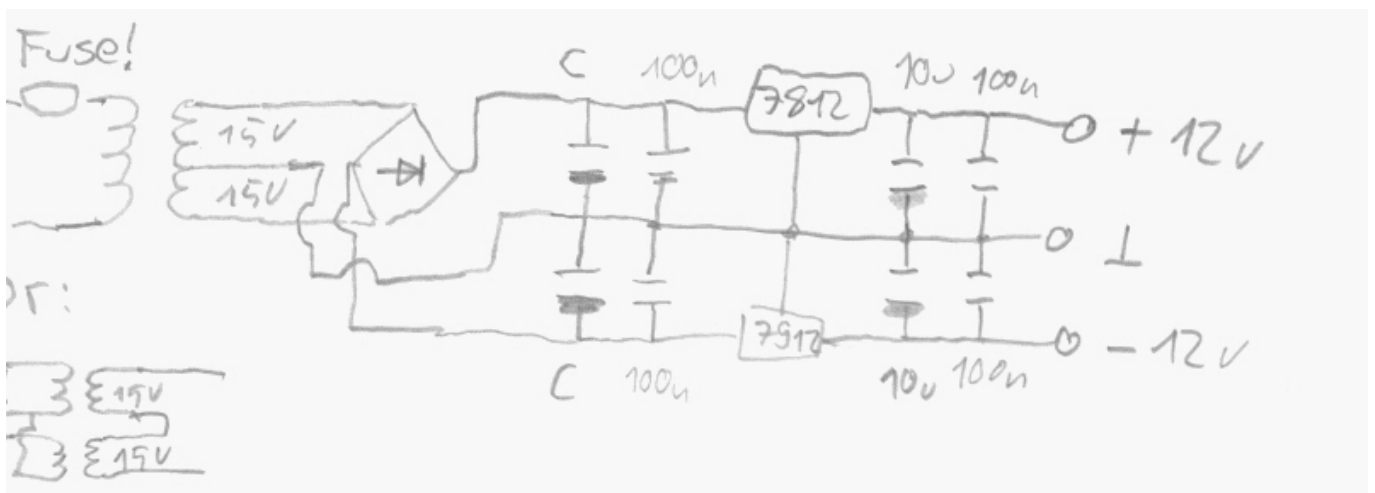

With a Single Transformer

The second drawing shows the same circuit, but driven from a single transformer. This is done with a circuit called voltage doubler. Note that through one way rectification we get twice the ripple (hum), so the charging caps should have double size (see below). This circuit is included because wallmart or other cheap and safe supplies with a center tap are hard to find. AC supplies with a single transformer like in this example can be found much easier. Conrad in Germany sells a 14 VAC plug transformer that is safe, cheap and absolutley sufficient for small opamp designs. You have to take care that both sides are equally loaded! symmetry should be within 50 mA. Otherwise the transformer won't like it and get hot. I don't know if this method is good for Midibox projects since I don't know the exact currents consumed by the analog modules. But note that you can always connect two of these transformers in series. They can then be handled like a single transformer with center tap.

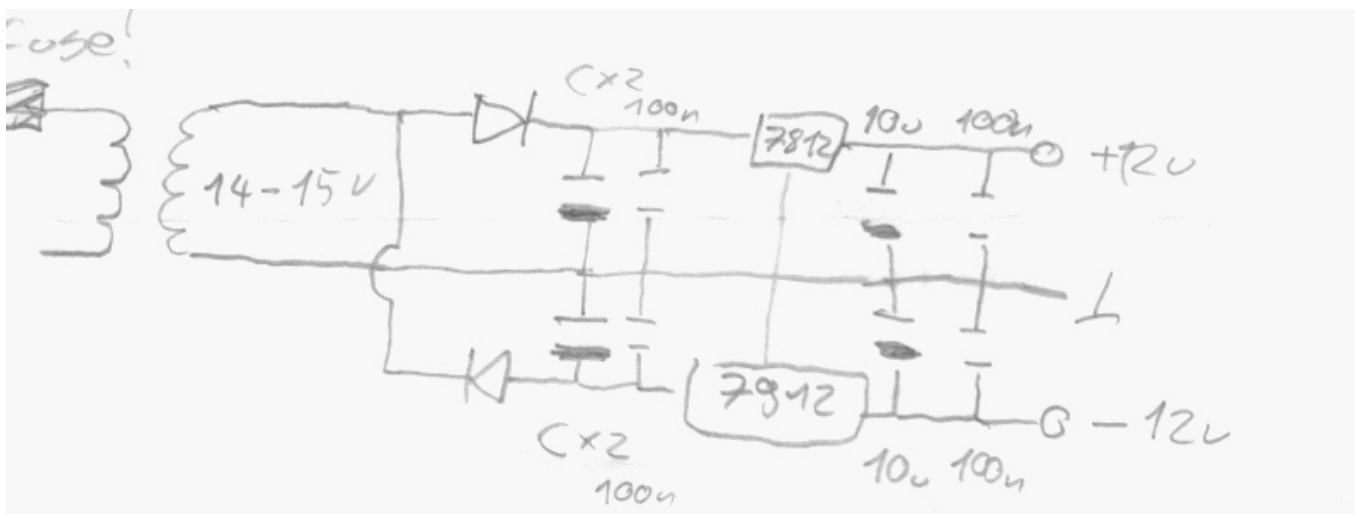

Connecting DC Supplies

Then there are two examples of how to connect two identical 12 V power adaptors. It is very important to use two identical ones! Same brand, same rating, best bought in the same shop the same day! You get these in regulated and unregulated versions. Best use the regulated ones and simply connect them in series. It's important to remember that there are situations where this is not ideal. Why? Instead of a positive and a negative regulator we here have two pos. regulators. One giving pos supply, one giving ground. The negative supply is the "ground" of the lower transformer. This should be no problem in this case, but may with heavy unbalanced load. (?)

For the last drawing I included a transistor circuit called gyrator. This will get rid of most of the hum when using unregulated supplies. With these it is, again, possible that their secondary voltage is much higher than what is printed on them. If it is at or above 15 V (under load!!!) you can also connect the 7812/7912 regulators instead of the gyrators. This should be preferred when working with opamps. The gyrator is not a regulator. It is the active equivalent of a coil. It filters hum. If the input voltage is too high, the output will also be high. Most opamps are limited to +/-18 V. If you want it to be absolutley free of hum (only needed for high gain circuits like mic preamps) you may want to use both regulators, followed by gyrators) The gyrator with the 50R series resistor cannot provide much current. Not sure how much, experts, please help.

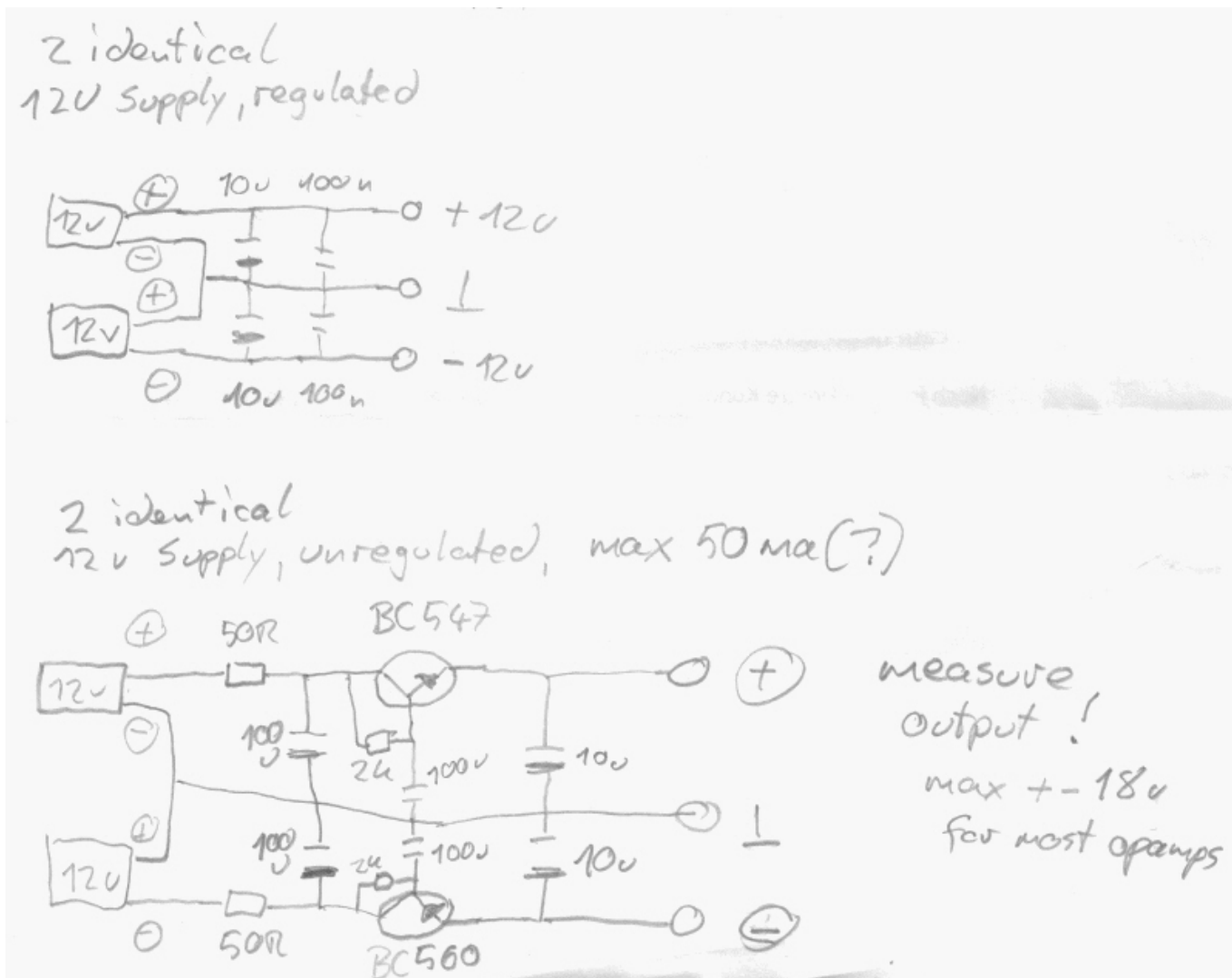

What Capacitor Size?

A standard rule I found in one place is 470 uF per 0,1 Ampere. That should be enough. Making the capacitor bigger is no problem (to a certain degree). For our projects I guess 1000 to 3000 uF should be absolutley enough. With the single no center tap transformer psu make them twice the size!

A Word about "Wall Warts"

Most people like to use these because they are cheap and considered safe. But watch out! In Germany there was a test where 1 out of 3 PSUs didn't match the safety standards. In most cases current and voltage rating was not correct, making the transformer run hot. In these cases the units were really dangerous! Don't trust what's printed on a cheap transformer. Lables like "CE" are no guarantee. german link:

http://fhh1.hamburg.de/fhh/aktuelle_meldungen/archiv_2001/oktober/pe_2001_10_16_bags_02.htm

I recommend not to get the cheapest noname supply, but a quality one. When connecting a new one you should check after some time if the unit is getting hot. It can be warm, but never hot!

From:

<https://www.midibox.org/dokuwiki/> - **MIDIbox**

Permanent link:

https://www.midibox.org/dokuwiki/doku.php?id=bipolar_12v_psu&rev=1236481855

Last update: **2009/03/08 03:10**

