

# Envelope Follower

based on Harry Bissel

a SMD Variant, ready for Pick and Place

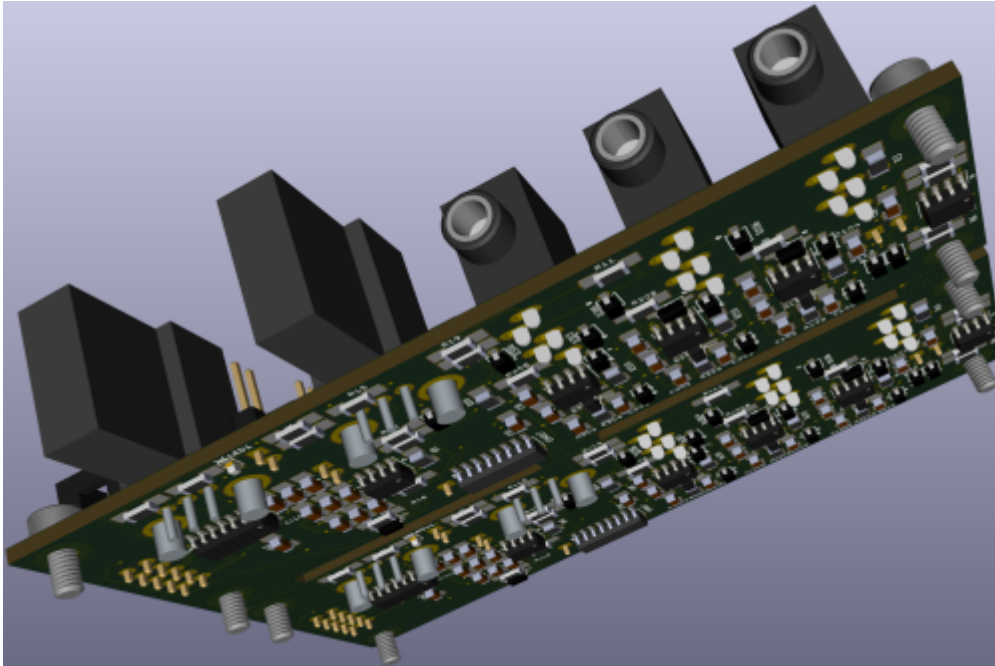

-shown 2 identical boards on one pcb - to save money..

## Features

- \* audio in \* Envelope out \* Gate out + Gate Threshold-Poti
- \* Full-wave rectifier
- \* 3 identical Peakdetectors which are Reseted from a "stepper"
- \* a Oscillator with tunable Frequency to drive the stepper
- \* Smoothingcap set via Jumper
- \* Debugging Jumpers
- \* PTC and Diode Polarity Protection on the Supply-side

## Hardware Requirements

- This Device i build as input module for my [CV1](#) Project, but can be used for other things too
- Soldering Iron - with a Dip that can Handle SMD-Parts, Wires, solder Paste...
- Eurorack Power Source +-12V!

## Building

The Design is optimized for Pick and Place most SMD Parts are on the Top-PCB

i ordered 5 PCBs from JLCPCB with almost all SMD Parts presoldered(except 2 SOIC chips PTC and Protection Diode)  
 now waiting for Presoldered PCBs

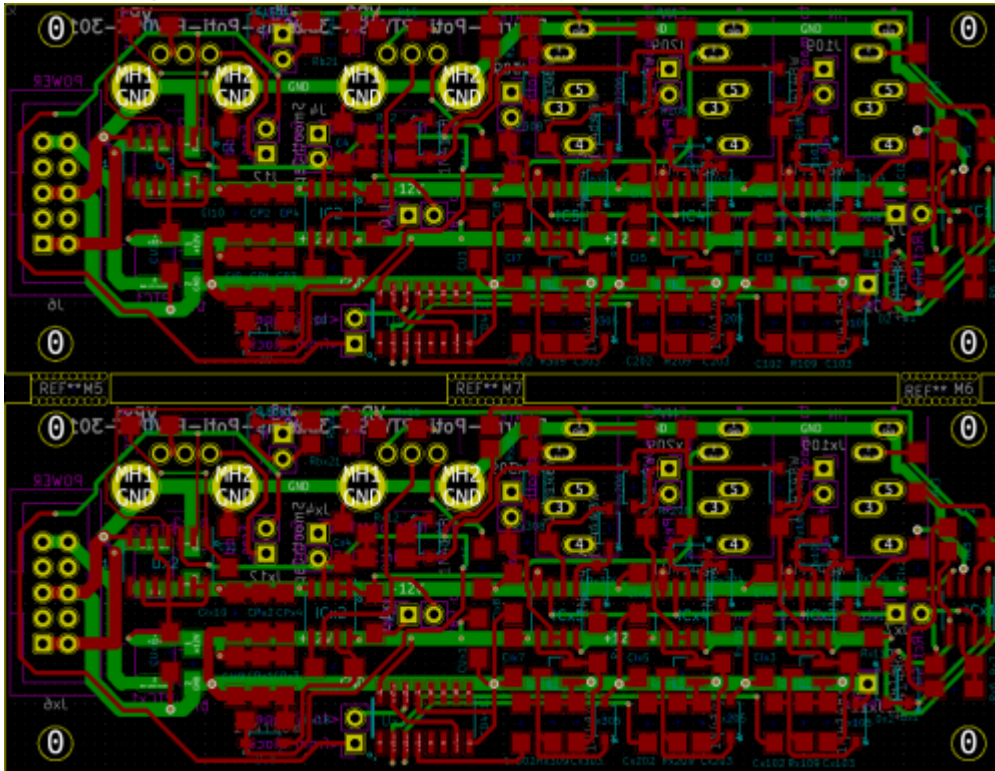

## Frontpanel



## BOM LCSC

these are the parts which are presoldered by the Pick and Place Machine, these are “Basic” Parts the values with a “x” in it, like Dx1 — are because there are 2 Identical Parts on 1 PCB, because there 2PCBs on 1PCB.... so Dx1 is the same like D1, but its position is on the second board.

Value	Designator	Footprint	LCSC Part Number	Library-Type
100nF	C1,CU1,C11,C1x1,CU1,Cx1,CU2,C12,C1x2,CUx2,CP3,C13,C1x3,CPx3,CP4,C14,C1x4,CPx4,C4,Cx4,C15,C1x5,C16,C1x6,C17,C1x7,C18,C1x8,C19,C1x9,C110,C1x10	1206	C24497	
1nF	C102,Cx102,C103,Cx103,C202,Cx202,C203,Cx203,C302,Cx302,C303,Cx303	1206	C35216	
47uF	CP1,CPx1,CP2,CPx2	1206	C96123	
1N4148W	D1,Dx1,D2,Dx2,D7,Dx7,D8,Dx8,D103,Dx103,D104,Dx104,D105,Dx105,D106,Dx106,D203,Dx203,D204,Dx204,D205,Dx205,D206,Dx206,D303,Dx303,D304,Dx304,D305,Dx305,D306,Dx306	SOD123	C81598	
TL072	IC1,ICx1,IC2,ICx2,IC3,ICx3,IC4,ICx4,IC5,ICx5	SOIC-8	C6961	
2N3904	Q101,Qx101,Q201,Qx201,Q301,Qx301	SOT-23	C20526	
100K	R12,Rx12,R13,Rx13,R17,Rx17,R18,Rx18,R108,Rx108,R110,Rx110,R208,Rx208,R210,Rx210,R308,Rx308,R310,Rx310	1206	C17900	
1K	R1,Rx1,R8,Rx8,R11,Rx11,R20,Rx20,Ra21,Rax21	1206	C4410	
2K	R19,Rx19	1206	C17944	
10K	R3,Rx3,R4,Rx4,R5,Rx5,R6,Rx6,R7,Rx7,R15,Rx15,R16,Rx16,R109,Rx109,R209,Rx209,R309,Rx309	1206	C17902	
220	Rb21,Rbx21	1206	C17958	

when making 10Boards...a total of **42,44€** presoldered on the PCBsincl Shipping and Import-Taxes

## BOM Mouser

These are the parts which has to be handsoldered

[copy list below](#), and paste in this link, you will need to order the project 2 times since 2PCBs are on 1PCB

583-FM4002|2

490-SJ1-3535NG|3

523-G821EU210AAL10Y|1

650-MINISMDC014F-2|2

771-HEF40106BTD-T|1

595-CD4017BM|1

652-PTV09A-3015FB103|1

652-PTV09A3020FB104|1

when making 10PCBs this make a total of **53,58€** incl Shipping which is free above 50€!

There are 2 SOICs that have to get Handsoldered, i have done this before and its easy!

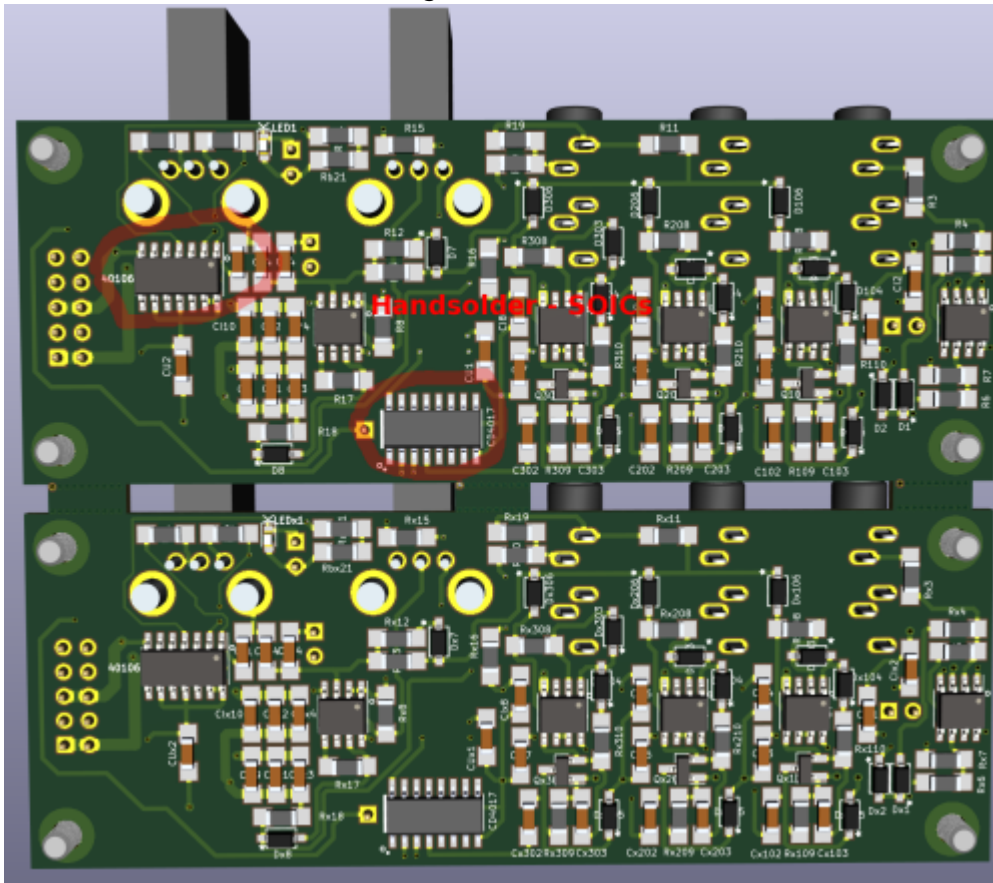

## Overall Material Costs

PCB:**42,44€** + MouserParts:**53,58** = 96,02€ / 10 PCBs = **9,602€**

(where half off work is done by pick and place machine!)

# Kicad Files & Production Files

V1. from 05.01.2021 [env-follower.zip](#)

Schematic, Board, Gerber, Pick and Place and Booms, ready for Pick and Place!

—at the moment untestet, since i order the project just now!

## Schematic

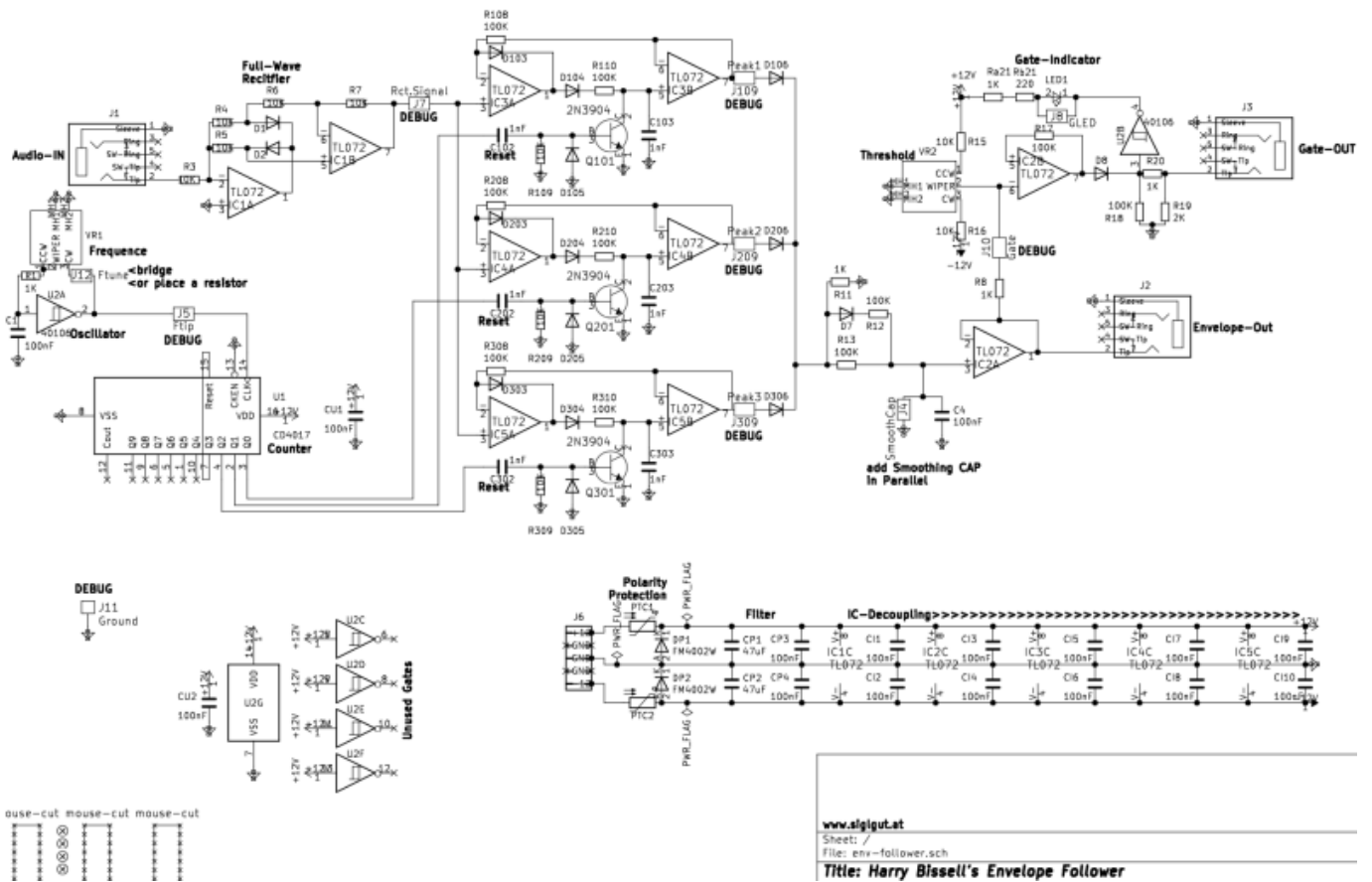

## To Do

- experiment with the Smoothing CAP, i already implimented a Jumper which add a second Capacitor to "double" the capacity... i took 220+220nF, but maybe it is better to use 100+220nF
- experiment with the Frequency Pot which is a lin10K + 2K Serial Resistor which gives a range of 2K-12K - really dont know what value spectrum we need here!
- adding some Jumpers to break the circuit for debugging or measurement frontplate, Debugging First Version

## Resources

[muffwiggler-topic](#)  
[modified-schematic](#)  
[THT-PCB](#)  
[THT-PCB-Schematic-BUT Attention it is not correct!](#)  
[THT-PCB-BOM](#)  
[Haralds-Hi-Clock-Measurements](#)

## Community users working on it

- **Phatline** = Programming, Documentation...

Just let a Private message on the forum to user already involved.

I have ProtoBoards here - i test one, and if it works, i can share them for Beta Testing-if you pay the postage

From:

<https://www.midibox.org/dokuwiki/> - **MIDIbox**

Permanent link:

<https://www.midibox.org/dokuwiki/doku.php?id=envelope-follower-bissel-based&rev=1609882366>

Last update: **2021/01/05 21:32**

