

## About

A DIN module is used to connect buttons and encoders to the Midibox. The Name comes from “Digital Input” and means that the module can detect two states: ON or OFF. It then sends this information to be processed by the [mbhp core module](#). It comes with multiple serial registers 74HC165; every register provides 8 digital inputs, which are sampled with the latch enable signal LD and shifted out with the clock signal CLK. The advantage of using such shift registers is, that they can be cascaded to a long chain without the need of more than 5 cables to the core module. The DIN board has been designed on a way which allows to cascade not only the ICs on the board, but also several DIN modules. But note that it depends on the firmware how much inputs are processed by the core module. For instance, the MIDIBOX64 allows to connect up to 64 buttons = 8 ICs = 2 \* DINX4, the MIDIO128 supports 128 inputs = 16 ICs = 4 DINX4 modules.

## Getting Started

- [Preparation](#)
- [soldering](#)
- [Wher to buy Parts](#)
- [etching\\_pcb](#)
- [terminating\\_cables](#)

### Special Instructions

- [smd\\_soldering](#)
- etc

## Details

### Pins

[DIN & DOUT pin table](#)

### PCB files

```
list 'em
```

### Schematic

```
you can do it
```

## List of parts

list

## Building it

### Building instructions

blah blah blah

### Connection to Core Module

Check the version of your Boards; if you're using SmashTV's Core that's equipped with double rows, you can build a split-cable to connect J8/J9 to a DIN and a DOUT:

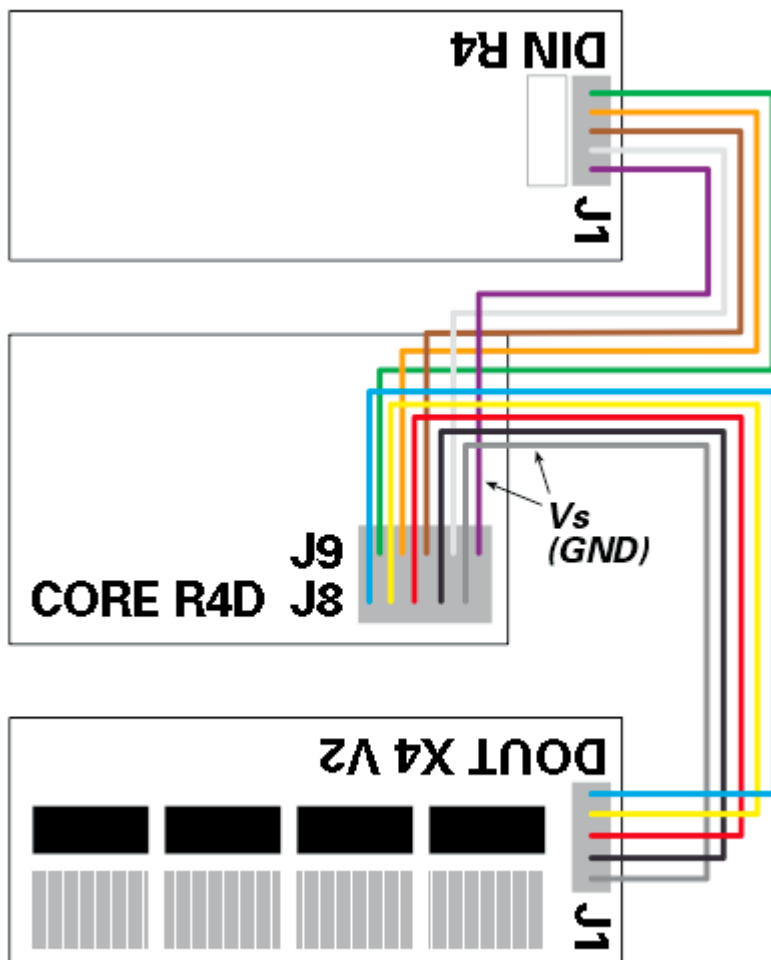

### Testing

testing instructions

## Common issues / Troubleshooting

blah blah blah

## Reference

[troubleshooting](#)

From:  
<https://www.midibox.org/dokuwiki/> - **MIDIbox**

Permanent link:  
<https://www.midibox.org/dokuwiki/doku.php?id=home:mbhp:module:din&rev=1228247756>

Last update: **2008/12/02 19:55**

