

PAD_4*4 module

A neat way to couple WS2812B programmable LEDs (pLEDs) with a silicone button pad (e.g. Sparkfun)

Schematic

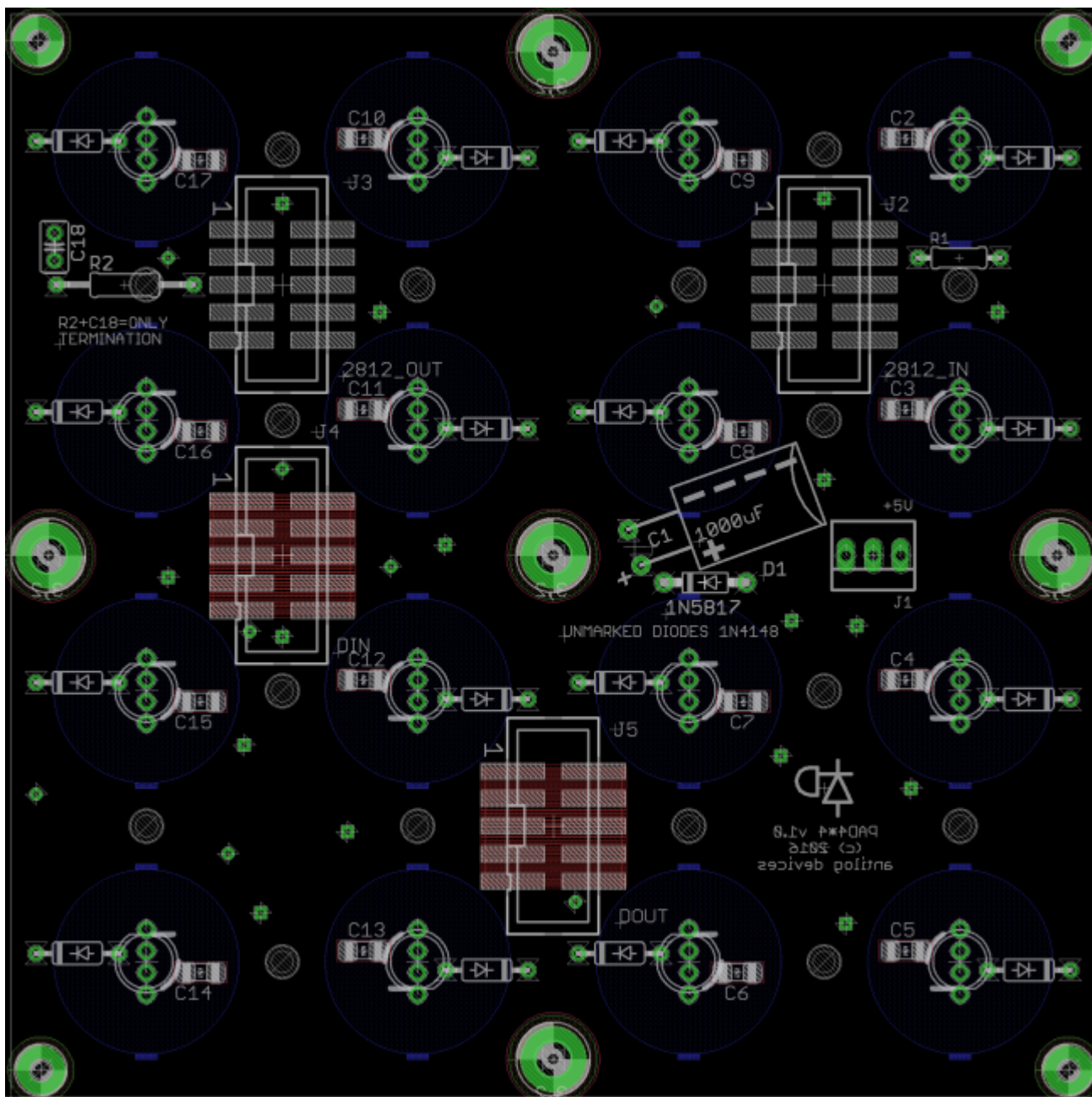

Rear view

Power input is +5V via a 3-pin 100mil connector (or Molex) and a Schottky diode. The value of electrolytic capacitor C1 is not critical.

The pLED chain enters via J2:pin 6 and resistor R1. The resistor should be replaced with a wire link for each additional module (i.e. only the first in the chain gets a resistor, the remainder stuffed with wire links). The serial chain then follows a snake pattern to J3, where additional pLED modules may be

connected. The RC (R2, C18) end termination shouldn't be necessary, but can be trialled should problems with signal reflection arise.



Front view

Switches are connected in a 4*4 matrix with the given mapping. D0 refers to pin 10 of the IDC header (i.e. top right) for both DIN and DOUT.

BOM v1.2

Type	Qty	Value	Package	Parts	Notes
resistors					
	1	220-470R	0204/7	R1	replace with wire link for each additional module
capacitors					
	16	100n	1206	C2-17	
	1	100-1000u	electrolytic 3,5-6	C1	
	4	optional	025x050	C2, C4, C6, C8	can use another e.g. 10pF cap here for more filtering
diodes					
	1	1N5187	DO41-7.6	D1	
	16	1N4148	DO41-7.6	remaining axial diodes	

Type	Qty	Value	Package	Parts	Notes		
resistors							
	16	WS2812B	5mm	programmable LEDs		switches	
	1		Sparkfun 4×4 pad				headers
	4		2*5 (shrouded) SMT	J2-5			
	1		1X03_SMALL	J1	can use Molex 22-23-2031		
misc							
	1	acrylic bezel					

Versions

v1.2: first release.

Assembly

Putting the board together is simple. As usual, start with the flattest components and work your way up.

Resistors

- four 30k resistors marked in pink
- remainder are 49k9
- for best results, match R1/R2, R7/R8 (and so on), and R4/R5/R6, R10/R11/R12 (and so on).
- the value is less important than the minimum deviation.

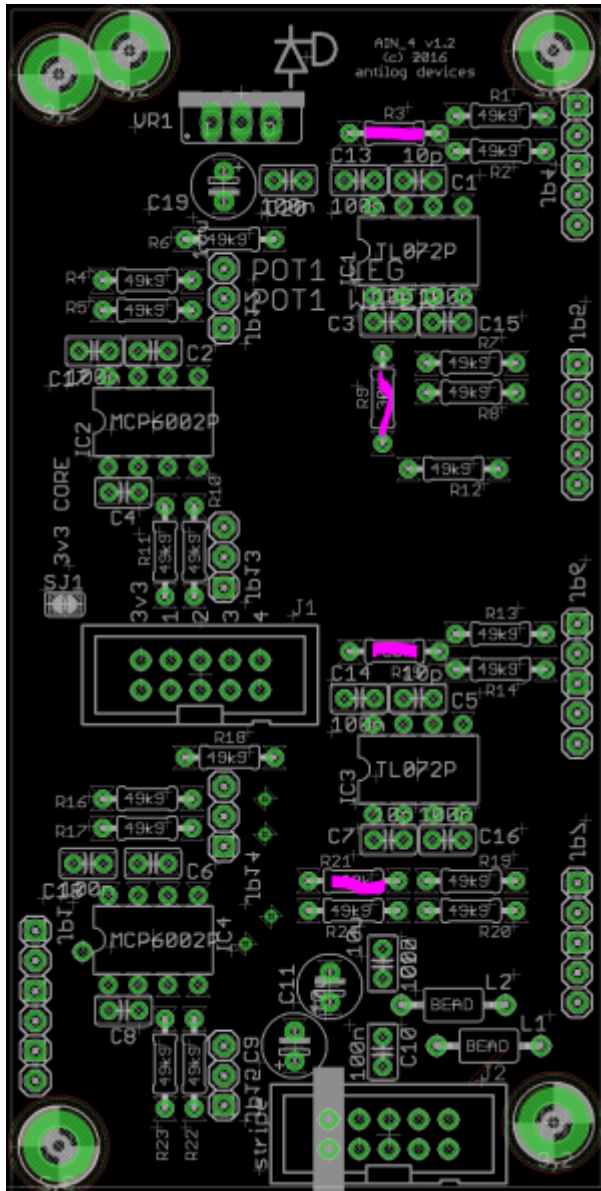

Capacitors

- four 10p as marked in pink
- electrolytics in yellow
- blue are optional (i.e. probably unnecessary)
- remainder are 100n.



Power

- J2 is a standard Eurorack header
- red = -12V
- blue = +12V
- green = 0V(ground)
- for Core power, bridge the solder jumper marked in yellow
- otherwise install the Vreg circuit in pink
- **IMPORTANT** only choose one of these 3v3 power options! Don't install the regulator if the solder jumper is bridged.

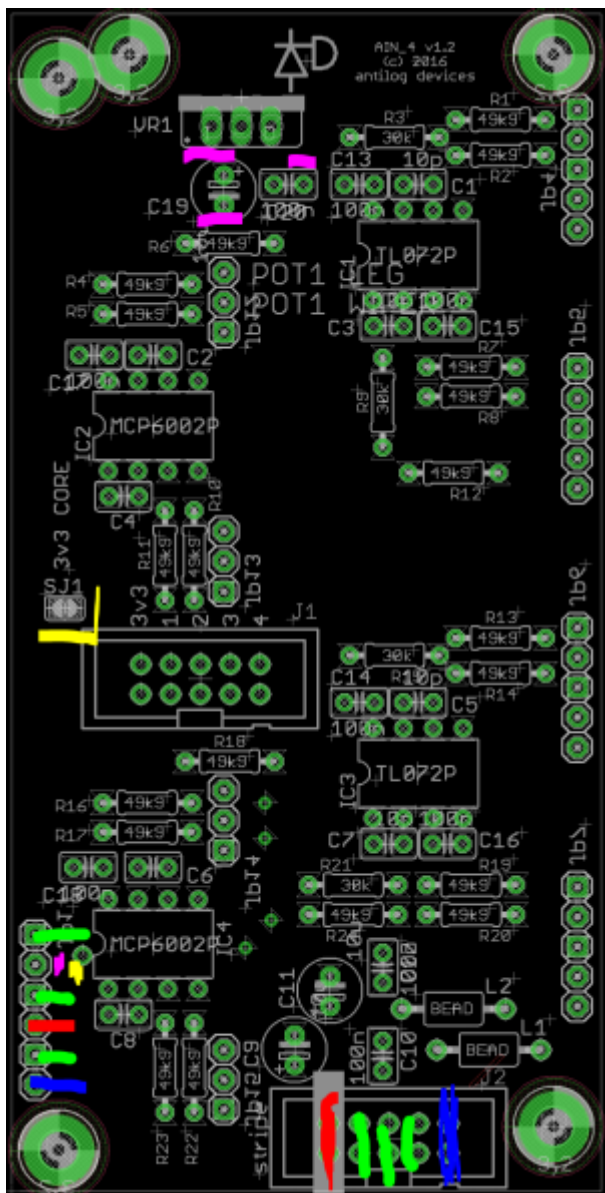

Headers

For connection to a [Control Board](#), use pin headers placed on the opposite side as the rest of the components i.e. follow the silkscreen markings. For standalone use, you probably want header pins (or sockets, or even bare wires if you wish) on the same side as the remaining circuitry.

Standalone use

For simplest results, use the complementary [Control Board](#). Otherwise see below for header functions.

Five pin header

- IN = CV input
- for scaling bipolar CVs, connect or switch into OFFSET (e.g. +5V; n.b. the offset should be

referenced to the common 0V)

- for 0-5V operation, leave SWITCH open; for 0-10V operation, jumper or switch in COMMON to POLE

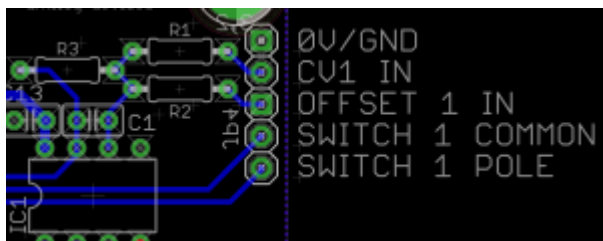

Three pin header

- with a 100k pot facing you, solder the left leg to 0V(ground)
- centre to WIPER
- right to LEG
- WIPER and LEG may be jumpered if pots aren't desired, but it is quite useful to have an attenuator to trim down variable CVs or even clip the second op amp for crunchy waveforms!

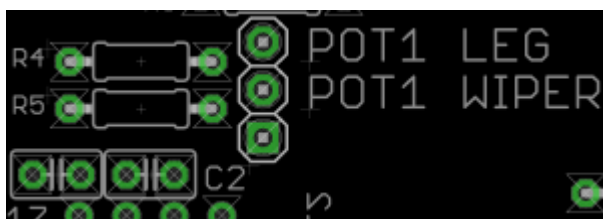

Interconnection to Core

J1 carries the scaled CV to J5A or J5B of an STM32F4 Core module.

License

Currently the design is © 2016 antilog devices with all rights reserved; all documentation is CC BY-NC-SA 3.0.

From:
<https://www.midibox.org/dokuwiki/> - **MIDIbox**

Permanent link:
https://www.midibox.org/dokuwiki/doku.php?id=pad_4_4&rev=1470867683

Last update: **2016/08/10 22:21**

